

300 SERIES DOOR CLOSER WITH FORGED HOLD OPEN ARM INSTALLATION

Optional Hold-open arm. Identify direction of hold-open nut according to mounting.

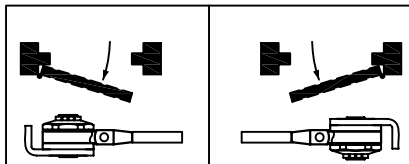

Optional Hold-open arm. Identify direction of hold-open nut according to mounting.

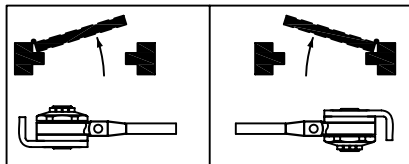

REGULATING DOOR SPEED AND LATCHING SPEED

TURN SPEED REGULATING VALVE CLOCKWISE TO SLOW COUNTER-CLOCKWISE TO SPEED UP DOOR MOVEMENT

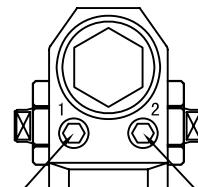

THIS VALVE CONTROLS DOOR SWEEP SPEED THIS VALVE CONTROLS LATCHING SPEED

REGULATING SPRING POWER REGULATING BC POWER

POWER ADJUSTMENT SCREW. TURN THIS SCREW CLOCKWISE TO INCREASE OR COUNTER CLOCKWISE TO DECREASE.

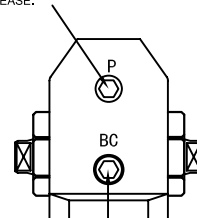

TURN BC REGULATING VALVE CLOCKWISE TO INCREASE OR COUNTER CLOCKWISE TO DECREASE. NEVER CLOSE THIS VALVE COMPLETELY.

POSITION OF ARMS AND INDEX SETTINGS

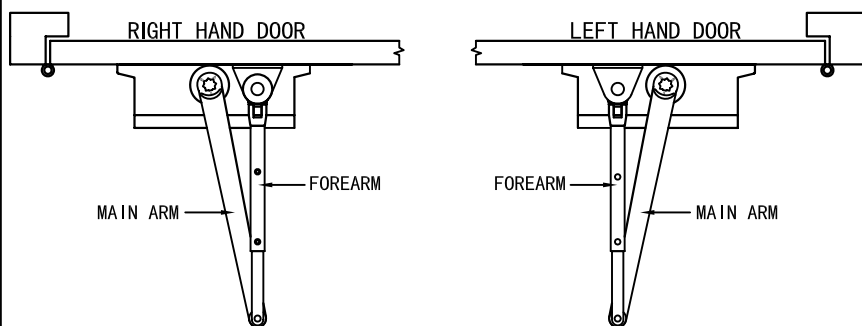

CLOSING SPEED CONTROL

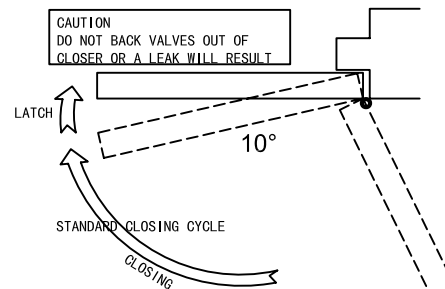

ATTENTION:

ADJUST CLOSING SPEED TIME TO BETWEEN 4 TO 6 SECONDS FROM 90° USE OF THE DOOR BY HANDICAPPED, ELDERLY OR SMALL CHILDREN MAY REQUIRE LONGER CLOSING TIME.

◆ STANDARD INSTALLATION: PULL SIDE RIGHT INSTALLATION

- RIGHT HAND DOOR ILLUSTRATED SAME DIMENSIONS APPLY TO LEFT HAND DOOR
- MEASURED FROM HINGE C DIMENSIONS ARE IN ^{inches} (mm)
- DO NOT SCALE DRAWING

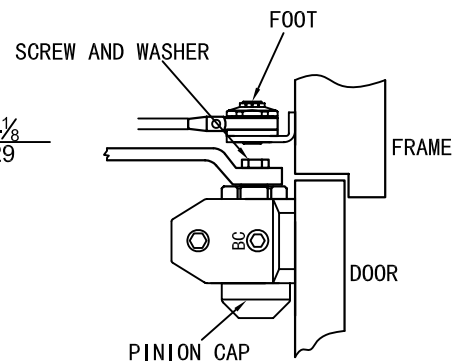
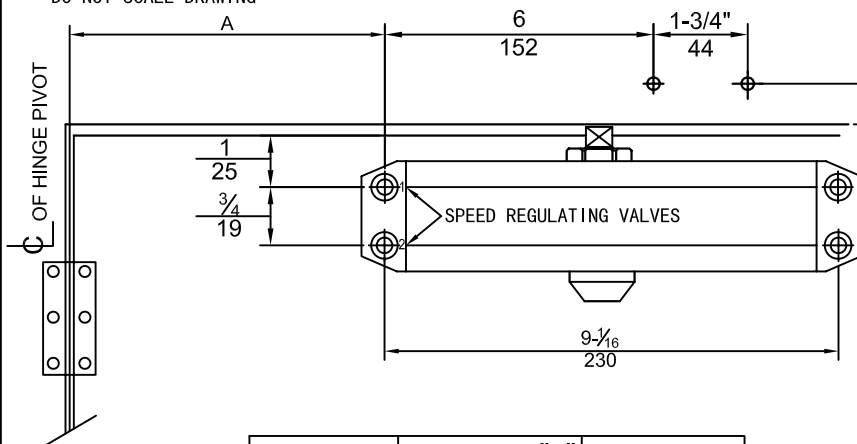

INSTALLATION INSTRUCTIONS

1. SELECT DEGREE OF DOOR. USE DIMENSIONS SHOWN IN CHART AND ILLUSTRATION ABOVE TO MARK LOCATION OF ATTACHING SCREWS. ON DOOR AND FRAME PREPARE HOLES.
2. ASSEMBLE MAIN ARM TO CLOSER.
3. ATTACH CLOSER TO DOOR WITH SPEED REGULATING VALVES TOWARD HINGE.
4. ATTACH THE FOOT OF THE FOREARM TO FRAME.
5. ADJUST LENGTH OF FOREARM TO POSITION FOREARM AT RIGHT ANGLE TO FRAME TIGHTEN THE SCREW OF FOREARM.
6. SNAP PINION CAP OVER SPINDLE AT BOTTOM OF CLOSER.
7. ADJUST DOOR CLOSER.
8. LOOSEN THE INNER HEX SCREW AT THE ELBOW OF THE FOREARM, OPEN THE DOOR TO THE ANGLE YOU NEED, THEN TIGHTEN THE INNER HEX SCREW TO HOLD THE DOOR OPEN.

MODEL	DIMENSIONS "A"		OPENING
	inches	mm	
300	7"	178	T0 100°
	6"	152	101° T0120°
	3-1/2"	89	121° T0180°

◆ OTHER INSTALLATION: PUSH SIDE TOP JAMB INSTALLATION

- LEFT HAND DOOR ILLUSTRATED SAME DIMENSIONS APPLY TO RIGHT HAND DOOR
- MEASURED FROM HINGE ϕ DIMENSIONS ARE IN $\frac{\text{inches}}{\text{mm}}$
- DO NOT SCALE DRAWING

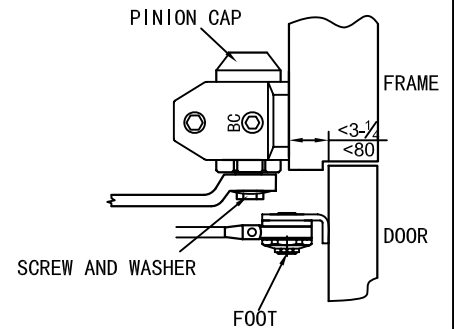
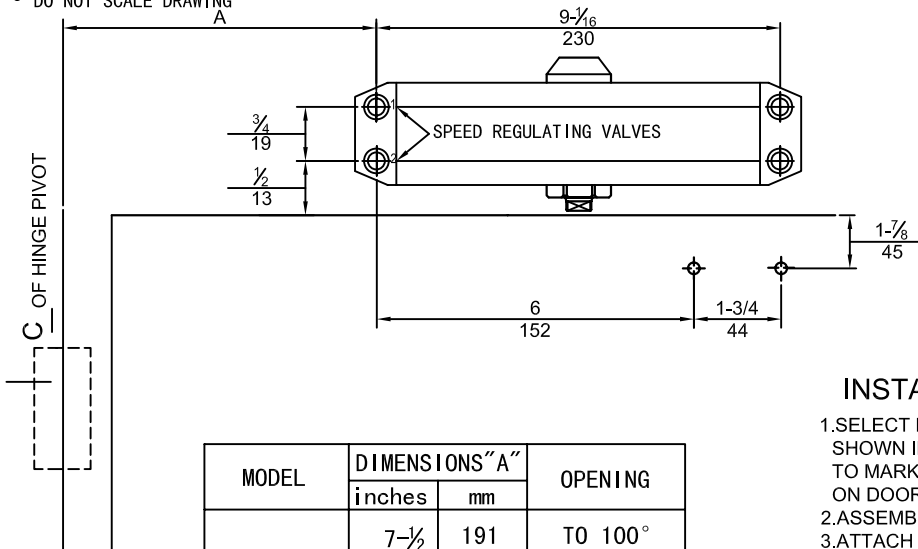

MODEL	DIMENSIONS "A"		OPENING
	inches	mm	
300	7- $\frac{1}{2}$	191	TO 100°
	6	152	101° TO 120°
	3- $\frac{1}{2}$	89	121° TO 180°

INSTALLATION INSTRUCTIONS

1. SELECT DEGREE OF DOOR. USE DIMENSIONS SHOWN IN CHART AND ILLUSTRATION ABOVE TO MARK LOCATION OF ATTACHING SCREWS. ON DOOR AND FRAME PREPARE HOLES.
2. ASSEMBLE MAIN ARM TO CLOSER.
3. ATTACH CLOSER TO DOOR WITH SPEED REGULATING VALVES TOWARD HINGE.
4. ATTACH THE FOOT OF THE FOREARM TO FRAME.
5. ADJUST LENGTH OF FOREARM TO POSITION FOREARM AT RIGHT ANGLE TO FRAME. TIGHTEN THE SCREW OF FOREARM.
6. SNAP PINION CAP OVER SPINDLE AT BOTTOM OF CLOSER.
7. ADJUST DOOR CLOSER.
8. LOOSEN THE INNER HEX SCREW AT THE ELBOW OF THE FOREARM, OPEN THE DOOR TO THE ANGLE YOU NEED, THEN TIGHTEN THE INNER HEX SCREW TO HOLD THE DOOR OPEN.

◆ OTHER INSTALLATION: PUSH SIDE PARALLEL INSTALLATION

- LEFT HAND DOOR ILLUSTRATED SAME DIMENSIONS APPLY TO RIGHT HAND DOOR
- MEASURED FROM HINGE ϕ DIMENSIONS ARE IN
- DO NOT SCALE DRAWING

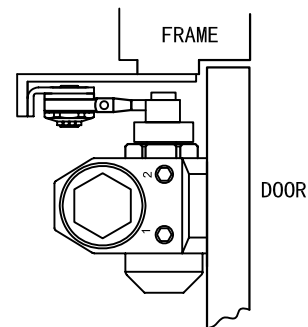
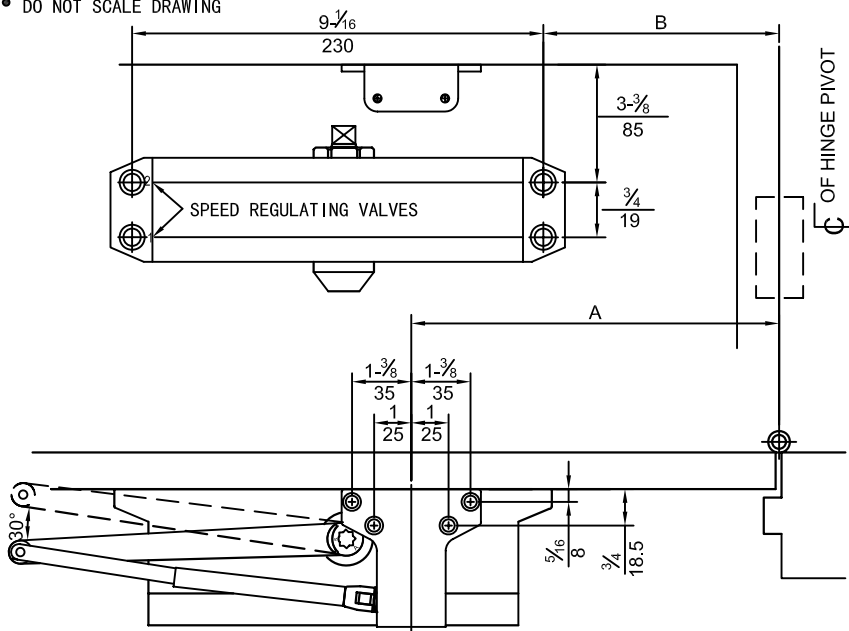

MODEL	DIMENSIONS "A"		DIMENSIONS "B"		OPENING
	inches	mm	inches	mm	
300	9	227	7- $\frac{5}{8}$	194	TO 120°
	7- $\frac{1}{2}$	190	6- $\frac{1}{8}$	156	121° TO 180°

INSTALLATION INSTRUCTIONS

1. SELECT DEGREE OF DOOR. USE DIMENSIONS SHOWN IN CHART AND ILLUSTRATION ABOVE TO MARK LOCATION OF ATTACHING SCREWS. ON DOOR AND FRAME PREPARE HOLES.
2. ATTACH CLOSER TO DOOR WITH SPEED.
3. ATTACH MAIN ARM AS FOLLOE:
 - (A) PLACE OPEN END WRENCH ON BOTTOM SHAFT & TURN TOWARD HINGE ABOUT 30°.
 - (B) PLACE MAIN ARM ON TOP SHAFT, INSERT ARM SCREW INTO TOP OF SHAFT AND TIGHTEN.
4. ATTACH PA PLATE TO TOP FRAME AS SHOWN.
5. FASTEN FOREARM TO PA PLATE.
6. ADJUST LENGTH OF FOREARM TO POSITION MAIN ARM AT PARALLEL TO FRAME WHEN CONNECTED TO MAIN ARM AT ELBOW. USE WASHER AND SCREW PROVIDED TO SECURE PIVOT CONNECTION. TIGHTEN LOCK NUT.
7. SNAP PINION CAP OVER SPINDLE AT BOTTOM.
8. LOOSEN THE INNER HEX SCREW AT THE ELBOW OF THE FOREARM, OPEN THE DOOR TO THE ANGLE YOU NEED, THEN TIGHTEN THE INNER HEX SCREW TO HOLD THE DOOR OPEN.