

INSTRUCTIONS FOR INSTALLATION OF ONE SIDED DEADBOLT

FOR USE ON DOOR THICK 1-3/8" (35mm) TO 1-3/4" (45mm)
TOOLS REQUIRED FOR REMODELING OR NEW CONSTRUCTION

1 phillips head screwdriver
1 1" (25.4mm) drill bit

1 2-1/8" (54mm) hole saw
1 chisel

1. MAKE DOOR

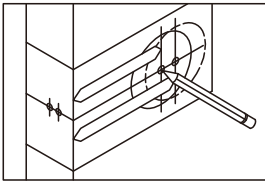

Start approximately 36" (914mm) from floor.
Fold and apply template on door edge and mark center of 2" (51mm) hole on door face.
(NOTE : Backset 2-3/8" (60mm) or 2-3/4" (70mm) on door face must match backset of your lock.)
Then make center of 1" (25.4mm) hole on door edge.

2. DRILL HOLES

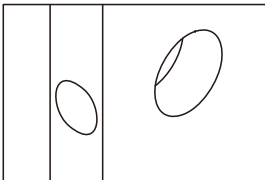

- a. Drill 2-1/8" (54mm) hole through door face.
It is recommended that hole be drilled from both sides to prevent splitting.
- b. Drill 1" (25.4mm) hole in center of door edge for latch.

3. INSTALL DEADBOLT

a.

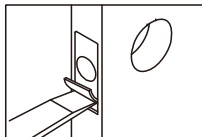
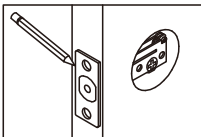

- a. Insert latch in hole, mark outline of faceplate and chisel 1/8" (3mm) deep.

- b. Insert latch and tighten screws.

- c. For drive in latch, drill 31/32" (24.6mm) hole and press latch until it is flush with door edge.

b.

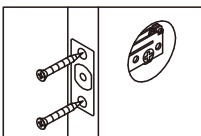

c.

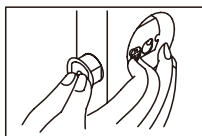

4. INSTALL DEADLOCK

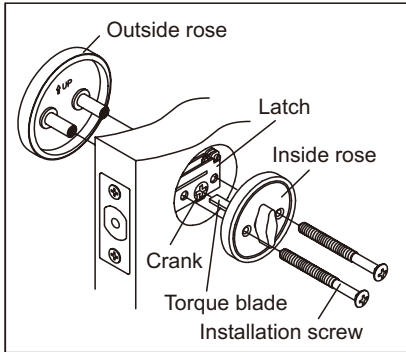

- a. Insert torque blade horizontally through crank.
- b. Align screw holes of inside rose, latch and outside rose. Insert screws and tighten until the lock is firm.

5. INSTALL STRIKE

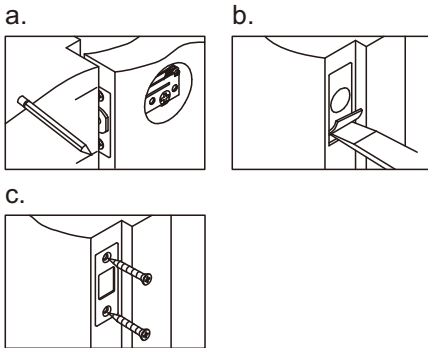

- a. Close door to make horizontal centre line of strike.
- b. Measure one half of door thickness from door stop and vertically mark centre line of strike. Drill 1" (25.4mm) hole, 1" (25.4mm) deep at intersection of horizontal and vertical line of strike. Mark outline using strike plate and chisel 1/16" (1.6mm) deep for strike.
- c. Install strike and tighten screws.

TEMPLATE

